

Part Number: PT212-3407C-31
 PT212-3407D-31
 PT212-3407C-02
 PT212-3407D-02

Kit Contents

Item #	Quantity Req'd.	Description
1	1	Tube Assembly RH & LH
2	1	Bracket Pack

Hardware Bag Contents

Item #	Quantity Req'd.	Description
1	1	LH Tube Assembly
2	1	RH Tube Assembly
3	2	Front Bracket
4	2	Mid Front Bracket
5	4	Rear Bracket
6	32	M8 x 25mm Sems Head Bolts
7	1	DIO Instruction Sheet

Additional Items Required For Installation

Item #	Quantity Req'd.	Description
1		

Conflicts

Note: Factory Running Board, Oval tube Running Board

Recommended Tools

Personal & Vehicle Protection	Notes
Safety Glasses	
Special Tools	Notes
None	
Installation Tools	Notes
Torque Wrench	3/8" Drive (25 lbs-ft)
Socket	10 mm (M8 bolt), 12 mm
Extension	3", 6"
Measuring Rule	Metric (mm)
Ratchet	3/8" Drive
Special Chemicals	Notes
None	

General Applicability

--

Recommended Sequence of Application







Item #	Accessory
1	

*Mandatory

Vehicle Service Parts (may be required for reassembly)

Item #	Quantity Req'd.	Description
1		
2		

Legend

-  **STOP:** Damage to the vehicle may occur. Do not proceed until process has been complied with.
-  **OPERATOR SAFETY:** Use caution to avoid risk of injury.
-  **CAUTION:** A process that must be carefully observed in order to reduce the risk of damage to the accessory/vehicle and to ensure a quality installation.
-  **TOOLS & EQUIPMENT:** Used in Figures calls out the specific tools and equipment recommended for this process.
-  **REVISION MARK:** This mark highlights a change in installation with respect to previous issue.
-  **SAFETY TORQUE:** This mark indicates that torque is related to safety.



Care must be taken when installing this accessory to ensure damage does not occur to the vehicle. The installation of this accessory should follow approved guidelines to ensure a quality installation.

These guidelines can be found in the "Accessory Installation Practices" document.

This document covers such items as:-

- Vehicle Protection (use of covers and blankets, cleaning chemicals, etc.).
- Safety (eye protection, rechecking torque procedure, etc.).
- Vehicle Disassembly/Reassembly (panel removal, part storage, etc.).
- Electrical Component Disassembly/Reassembly (battery disconnection, connector removal, etc.).

Please see your Toyota dealer for a copy of this document

1. Remove Vehicle Bolts

- ✚ (a) Working under a vehicle requires installer to wear safety glasses.
- (b) Remove hardware bag from carton, and verify content by referring to the instruction sheet.
- (c) Using 12 mm socket, remove and discard 7 left hand side, and 7 right hand side vehicle M8 bolts covering weld nuts used for bracket installation.

2. Assemble Vehicle Brackets LH

- (a) Obtain 1 front, 1 mid front, and 2 rear brackets. (The brackets are labeled for ease of identification)
- (b) Align front bracket with front vehicle weld nuts. Thread two bolts and finger tighten (Fig. 2-1).
- (c) Align mid front bracket with mid bracket holes in vehicle. Thread two bolts and finger tighten (Fig. 2-2).
- (d) Align rear brackets (final two positions). Thread two bolts per bracket and finger tighten (Fig. 2-2).

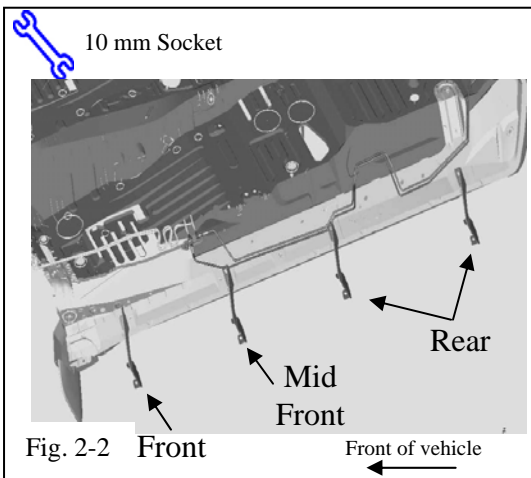

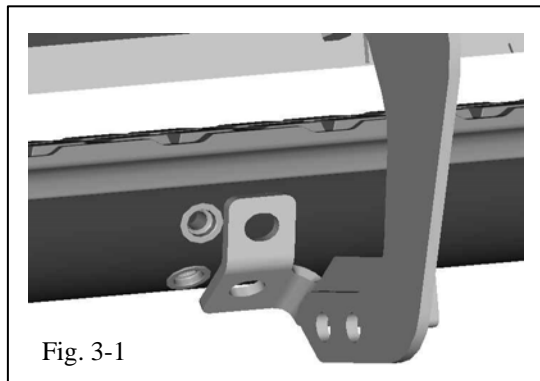

3. Installation of Tube Step LH.

- (a) Locate left hand tube and align mounting holes in tube with mounting holes on bracket (Tubes are labeled RH and LH) (Fig. 3-1).
- (b) Thread in two M8 sems bolts per bracket location, through bracket, and into threaded holes in tube. Install finger tight (8 Places) (Fig. 3-2).

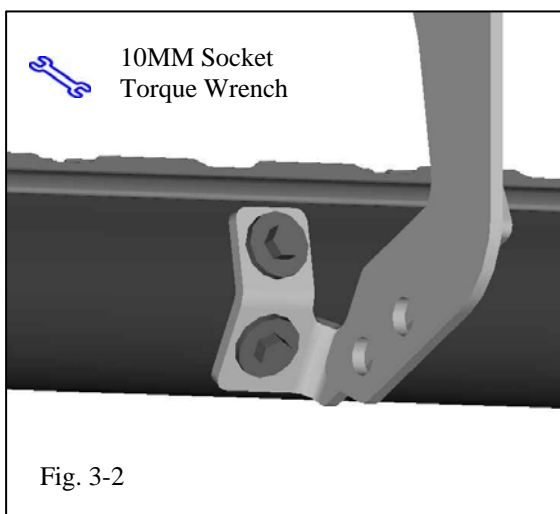

4. Final Alignment and Torque of Bolts

- (a) Visually align tube step to be centered on vehicle and parallel to body (Fig. 4-1).
- (b) Torque all fasteners to rocker panel to 19.5 Nm (14.4 ft-lbf).
- (c) Torque all bracket to running board fasteners to 19.5 Nm (14.4 ft-lbf).

⚠ Torque: 19.5 Nm (14.4 ft-lbf)

⚠ Torque: 19.5 Nm (14.4 ft-lbf)

- (d) Repeat above steps for right hand side.

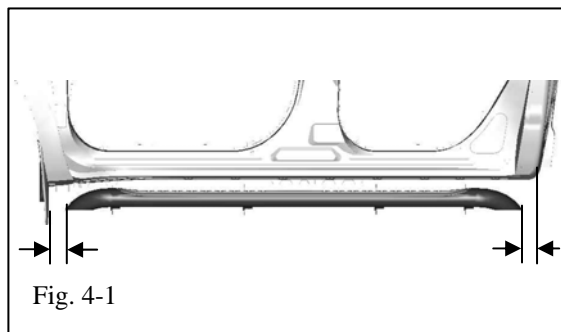

Checklist - these points **MUST** be checked to ensure a quality installation.

Check:

Look For:

Accessory Function Checks

- Visual check of running board.

Visually centered between wheel wells.
Visually parallel to vehicle side body.

Vehicle Appearance Check

- After accessory installation and removal of protective cover(s), perform a visual inspection.

Ensure no damage (including scuffs and scratches) was caused during the installation process.
(For PPO installations, refer to TMS Accessory Quality Shipping Standard.)